

Details: Yoke & Tie Installation

Complete the bracing process by attaching the VBUCK brand Yoke & Tie or double Yoke & Tie system to side members of block-out. For best results, follow all bracing instructions .

1

Fasten Yoke & Tie, one for 16" block; two for 24" block.

Push button into hole until you hear or feel a click.

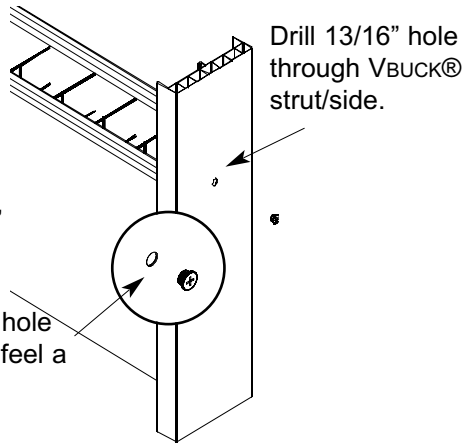

2

Assemble Yoke & Tie by sliding wire yoke through hole in tie end.

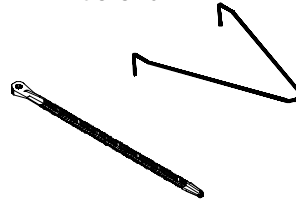

3

Clip yoke over second or third interior web of ICF block and slide tie through button.

After wall is stacked, and top course is placed apply foam adhesive every 18" to adhere VBUCK® to ICF .

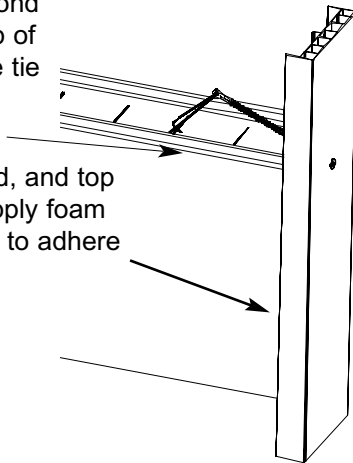

4

Slide tie tightly through button to secure VBUCK® to block.

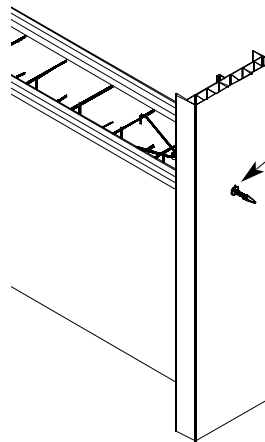

VBUCK®

U.S. PAT. 5,996,293 & 6,070,375
Canadian PAT. 2,255,256